

MAYTAG D21 DRYER

Installation Specification - Dimensions shown in millimetres

I/DE/G/21/09/04

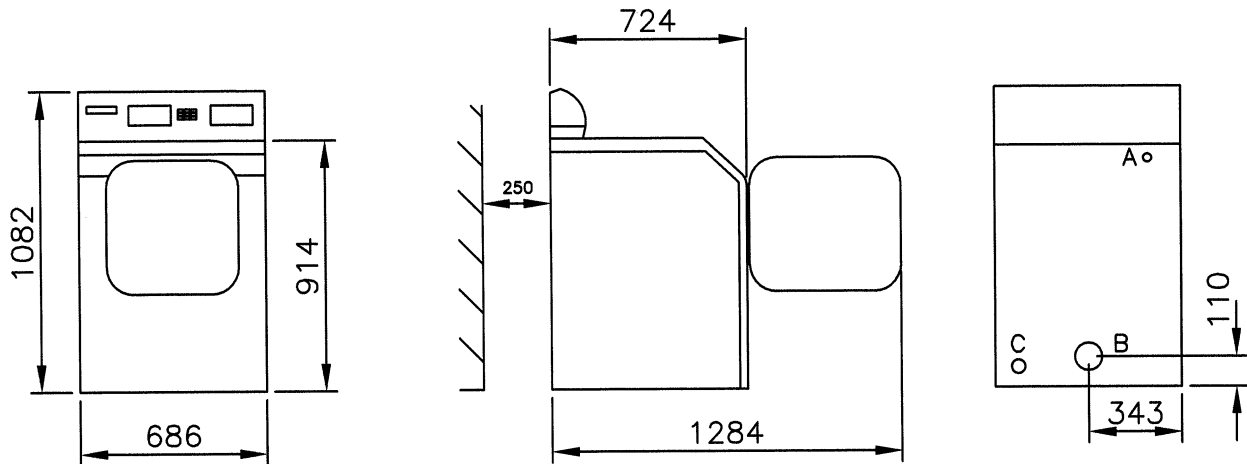

A - Electrical Connection, B - Exhaust Duct, C - Gas Inlet

Model		DE/G21
Dimensions (HxWxD)	Coin operated	1130 x 686 x 724mm
	Manual	1082 x 686 x 724mm
Boxed		1190 x 790 x 750
Weight	Nett	66kg (145lb)
	Loaded	78kg (172lb)
Electrical services		
Standard gas		240v/50Hz/1ph/13A
Standard electric		240v/50Hz/1ph/32A - 4.8kw
Motor rating		350 watt
Gas		
Heat input		5.86 Kw (20,000Btu)
Supply pressure	Natural gas	15mb (6"wc) min - 30mb(12"wc) max - above 30mb a regulator must be fitted.
	LPG	Propane 37mb (14.8"wc) Butane 28mb (11.2"wc)
Inlet size		1/2" BSP male via a 1/2" flexible amoured hose
Exhaust & Ventilation - Recommended Guides		
Exhaust outlet size		100mm (4") dia
Total max. length	Horizontal	16.5m (54ft) This allows for the use of 1 No 90 degree bend.
	Vertical	11.0m (36ft) This allows for the use of 1 No 90 and 1No 180 bend.
Max permissible exhaust back pressure		1.48mb (0.3"wc)
Airflow	Gas/electric	5.0m ³ (180ft ³)/min
Free air intake requirement		0.013m ² (20in ²)
Minimum installation distance - rear		250mm

Foundations

The machine should be sited on a firm level floor capable of withstanding its loaded weight.

Electrical

Single phase - Each machine must be provided with a separate isolation point, usually a fused switched spur outlet. Electrical connections are made at the rear located at the upper right of the machine. Ensure that the machine is also earthed correctly. The isolator must be in an accessible position for emergency shut off. A competent installer must carry out all work. All work and materials must comply with local and national codes of practice. The machine must be installed using correctly sized cable (not provided) and an appropriate protection device, i.e. fuse or circuit breaker.

Gas Supply

Ensure that the correct pressure is supplied to the unit depending upon the type of gas used, if the inline pressure exceeds the max permissible pressure a regulator must be fitted. The machine is designed to burn at a certain rate, known as the Btu or kw rating of the appliance. To ensure that this rate is maintained the gas supply should remain constant. therefore the supply line must be correctly sized. Distance from the meter and other appliances on the same supply will have an effect on the pressure. Each unit should have a gas isolation tap, test nipple point and restraining wire/chain. The machine should be connected to a supply using a flexible armoured hose with union connector,(bayonet fittings must not be used) as vibrations could cause a solid connection to fracture. All gas work must be carried out by a registered CORGI gas installer and must comply with all relevant local and national codes of practice.

Exhaust

All exhaust ductwork must be designed by a competent operative to ensure that the installation does not have any detrimental effect on the performance of the dryer. The duct should follow the shortest possible route to atmosphere using the least number of bends possible and should be constructed of a smooth wall, rigid stainless steel or galvanized tubing. The diameter of the ducting should never be reduced in size and where possible 45° bends should be used in place of 90° bends. Rigid ducting should be used right upto the machine spigot wherever possible. If this is not possible flexible ducting can be used as a final connection only and should be limited to a maximum 0.5 metres in length and must not change direction. Plastic or foil flexible ducting must not be used, only use metal flexible such as rega-duct or steelflex duct. If a common duct is to be used to vent multiple dryer installations the diameter must be increased to accommodate the cumulative effect of all the dryers. Exhaust terminations for horizontal duct terminations should be via a downturn 90° elbow, vertical ducts to be terminated via inverted china hats or a 135° return. Conventional china hats (hoods) must not be used as this has a massive effect on back pressure. Louvres or grills may be used to prevent entry by foreign objects but consideration must be given to potential restrictions to air flow and must also allow easy cleaning of the grill or louver. Duct termination must be a minimum of 300mm and should ideally be 2 meters away from any opening or fresh air inlet into the building. The exhaust should be properly sealed at all the joints by duct tape(not rivets or screws). Larger diameter or rectangular ducting may require some additional fixing by screws or rivets but these must be kept to a minimum in number and length. In all cases adequate access must be made for cleaning purposes. Site conditions may vary and these should be taken into account when planning the exhaust system. It is recommended that the supplier is consulted for long, multiple and difficult ducting runs.

Ventilation

While in operation the dryer removes a large amount of air, from the room via the exhaust. Therefore the air inside the room must be continually replenished with fresh air from atmosphere. Ventilation must be fixed and unrestricted and sized to provide the correct amount of fresh air in take. Louvres and grills may be used but consideration should be given to any restriction imposed by them. Ventilation must be a minimum of 300mm and should ideally be 2 meters away from any exhaust duct termination. If more than one dryer is installed the opening should be increased to match their requirements; there is no need to make a separate opening. Where ventilation from outside is provided through a cavity, the cavity must be lined and sealed in a plenum box or suitable alternative. Site conditions may vary and these should be taken into account when planning the ventilation.

NOTES

- 1 WHERE EXISTING SERVICES ARE TO BE CONNECTED TO.THE INSTALLER MUST ENSURE THAT THESE ARE ADEQUATELY SIZED AND THAT THEY ARE IN GOOD WORKING ORDER. FOR EXAMPLE, IF A DRYER IS TO BE CONNECTED TO AN EXISTING EXHAUST IT MUST BE CHECKED FOR ANY BLOCKAGES DURING INSTALLATION AND BE CLEAR OF ANY LINT.**
- 2 FOR MULTIPLE MACHINE INSTALLATIONS SERVICES MUST BE INCREASED IN SIZE ACCORDINGLY. I.E EXHAUST DUCTING, GAS SUPPLY ETC.**