

HW164/35X WASHER

Installation Specification - Dimensions shown in millimetres

HW164/02/00/1

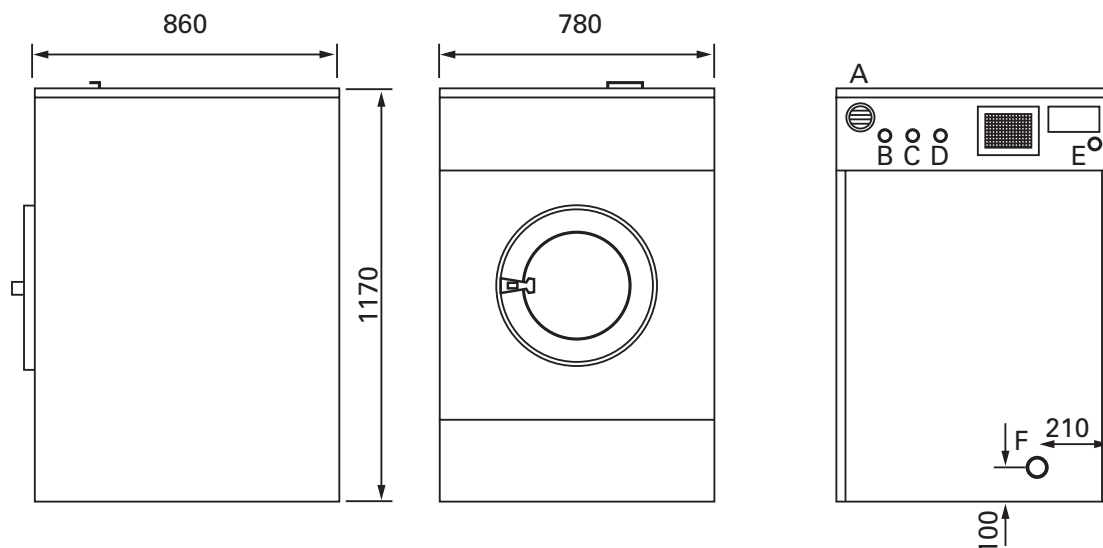

A - Ventilation Soap Dispenser, B - Hard Water Connection (cold), C - Warm Water Connection, D - Soft Water Connection (cold), E - Electrical Connection, F - Drain Outlet,

Model		HW164	
Dimensions (HxWxD)		1170 x 780 x 860mm	
Dimensions (HxWxD)		1320 x 850 x 1020mm	
Weight	Nett	347kg (764lb)	
	Loaded	446kg(983lb)	
Dynamic bottom load		1200N/16Hz	
Water			
No. of inlet valves	Coin Operated	1 hot & 1 cold (hard & soft)	
No. of inlet valves	Manual	1 hot & 2 cold (hard & soft)	
Recommended temperature (Hot water)		60°C	
Minimum pressure		25psi	
Inlet size		3/4" BSP	
Flow rate		27 litres/min per supply	
Average hot consumption		71 litres per cycle	
Average total consumption		324 litres per cycle	
Drain			
Size		50mm	
Electrical			
Three phase	Self-heat 12Kw	415v + N	32A/ph
	Boiler fed	415v + N	15A/ph (special order)
	Steam	415v + N	15A/ph (special order)
Single phase	Self-heat 6Kw	240v 50Hz	32A (special order)
	9Kw	240v 50Hz	45A
Steam			
Consumption		16.4Kg/cycle (36lb/cycle)	
Pressure		90 - 110psi	
Connection		3/8" BSP	

Foundations

The machine requires a foundation of solid and level concrete construction at least 200mm deep. If a new concrete pad is to be laid it must be keyed correctly into the existing foundations. The concrete foundation should always be greater in size than the machine and a minimum of 100mm from the edge of the concrete foundation to the edge of the machine must be provided.

It is recommended that a metal raising plinth is used in conjunction with the concrete foundation. This will make the installation considerably easier, simplify for future servicing and raise the machine above the drain level for a correct evacuation of water from the machine. A metal raising plinth **must** be used if the drain level of the machine needs to be elevated.

If block and beam or any type of floor with a void underneath is present, seek advice.

Fixings

A minimum service distance of 600mm is to be provided behind the machine (400mm if metal raising plinth is to be used). The machine needs to be securely fixed to the floor by 4 x M12 x 150mm fixing bolts. The type and specification of bolts will be determined by the quality and type of floor construction. The following types are generally accepted: rawlbolt, resin bonded fixings (chemfix) and Thru' bolts.

Water Supply

There are two standard configurations of machine,

(i) Manual operation: this is supplied with three water inlet valves, hot, cold hard and cold soft. If there is no soft water available or it is not needed, the soft connection must be connected to the same supply as the cold water inlet.

(ii) Coin operation: this is supplied with two water inlet valves, hot and cold.

TYPE 'A' MACHINES - This machine is fitted with its own Type 'A' Air Break System. This means that it can be connected directly to any water supply as certified by the WRAS.

NON TYPE 'A' MACHINES - Please note in accordance with the current water regulations this machine must be supplied with water (hot and cold) from a dedicated source with a Type 'A' Air Break System. Separate 22mm hot and cold supplies are required. If more than one machine is to be installed, then the pipe sizes should be increased accordingly. These supplies should terminate in 3/4" BSP shut off valves with male threaded ends.

If the hot water supply is insufficient in temperature, pressure or flow, the machine can then be connected solely to a cold water supply. This can only be done if the machine is equipped with a heating source, i.e. electric elements or a steam supply. This can increase cycle times and running costs.

A minimum supply pressure of 25psi is required: if this is not available cycle times will increase.

To overcome this a booster pump can be fitted: **PLEASE SEE SPECIFICATION FOR FLOW RATE REQUIRED.** The hot and cold supplies should be equal to within 25psi.

In hard water areas the machine must be supplied with soft water. Failure to do so will result in a detrimental effect on some component parts and may effect the standard warranty.

NOTE! ALL INSTALLATIONS MUST COMPLY WITH THE NATIONAL WATER REGULATIONS.

Drainage

The machine is fitted with a gravity drain outlet and subsequently should be positioned higher than the main drain. The drain outlet must be fitted with a "trap". This is to ensure against odour re-circulation. To meet Health and Safety guidelines the drain used must be sealed.

Electrical

The isolation point for the machine should be in a readily accessible position for use in an emergency. All cabling to the machine shall be sufficiently protected against damage. It shall be correctly sized to the current rating of the machine. It should be connected to the machine using a suitable cable entry fixing. The commissioning engineer will carry out the final connection inside the machine.

Circuit breakers or fuses can be used to protect the power supply. If fuses are used then they must be of the motor rated variety. It is also recommended that an earth leakage device protects the machine.

A responsible and competent operative should carry out all electrical work and ensure that all local and national regulations and codes of practice are complied with.

Steam (Optional)

The machine should be connected to suitably sized live steam supply utilising an isolating valve, strainer/trap, electric solenoid inlet valve and a flexible steam connection hose. **Please note none of these fittings are supplied with the machine.**

All pipes should be lagged to protect against personal injury. All steam supply pipes should be installed to local and national codes of practice as they form part of a pressurised system.